

CONTENTS

ABOUT THE USER MANUAL	2
FUNCTION SUMMARY & BUTTON DEFINITION	3
FUNCTION SUMMARY.....	3
FULL VIEWING AREA.....	4
NORMAL VIEWING AREA	4
BUTTON DEFINITION	5
NORMAL OPERATION	5
ON/OFF.....	5
DISPLAY INTERFACE	6
PUSH CRUISE CONTROL.....	6
TURN ON/OFF BACKLIGHT.....	7
PAS LEVEL SELECTION	7
BATTERY INDICATOR	7
ERROR CODE DISPLAY.....	8
USER SETTING	9
PREPARATION BEFORE STARTING.....	9
GENERAL SETTING	9
Distance and Riding Time Clearing.....	9
Wheel Size Setting.....	9
KM/H, MPH Setting	11
FAQ	12
QUALITY ASSURANCE AND WARRANTY SCOPE	12
WARRANTY:.....	12
OTHER ITEMS:	12
ERROR CODE DEFINITION	13
TABLE 1.....	13

Dear users,

To ensure better performance of your e-bicycle, please read through the C100 product introduction carefully before using it. We will use the most concise words to inform you of all the details (including hardware installation, setting and normal use of the display) when using our display. Meanwhile, the introduction will also help you solve possible confusion and malfunction.

Outlook and Size

Material and Color

C100 products are made of black PC material. Under the temperature of -20°C to 60°C , the shell material can ensure normal usage and good mechanical performance of the products.

Real product and dimension figure (unit: mm)

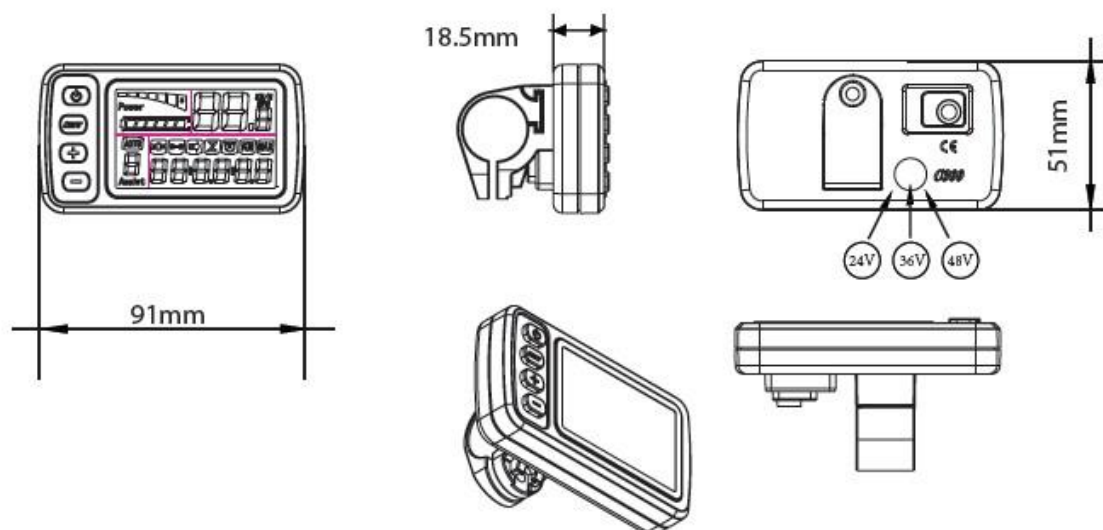

Function Summary

C100 provides a wide range of functions and indicators to fit the users' needs. The indicated contents are as follow :

- ◆ ODO Display ;
- ◆ Riding Distance Display ;
- ◆ Riding Time Display ;
- ◆ 6KM/H Display ;
- ◆ Backlight Open ;
- ◆ Assist Level ;
- ◆ Battery Indicator ;
- ◆ Error Code Display ;
- Wheel Diameter Setting ;
- KMH, MPH Switching ;
- Max Speed Limit Setting ;

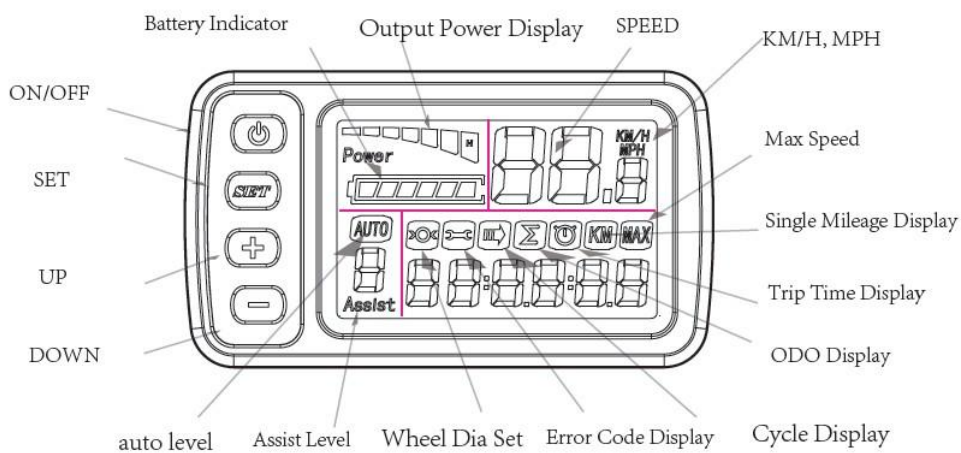

Full Viewing Area

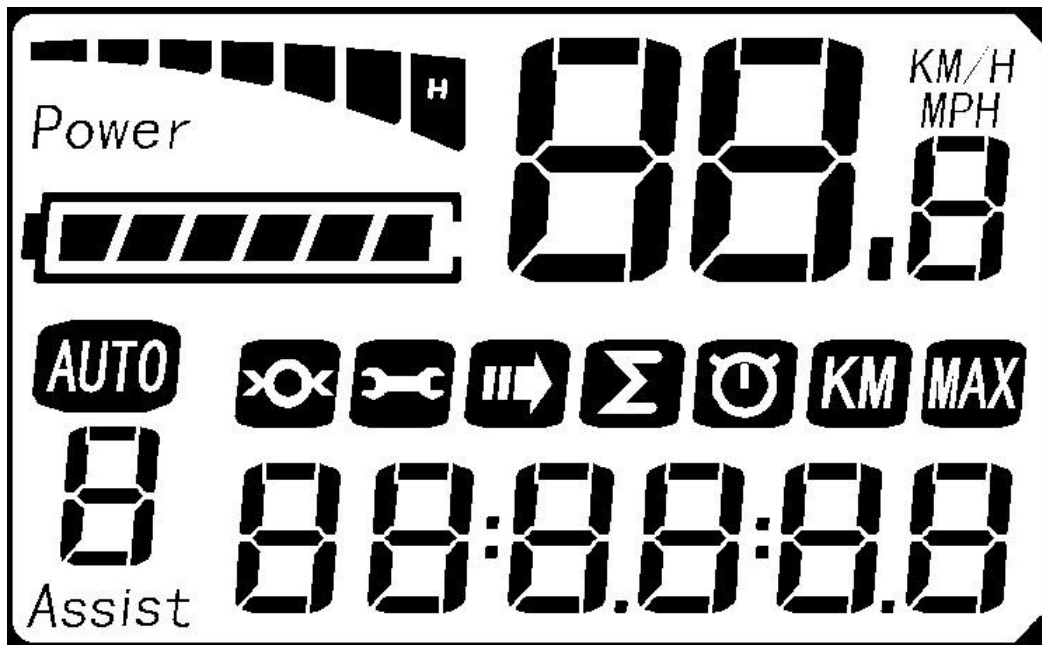

Normal Viewing Area

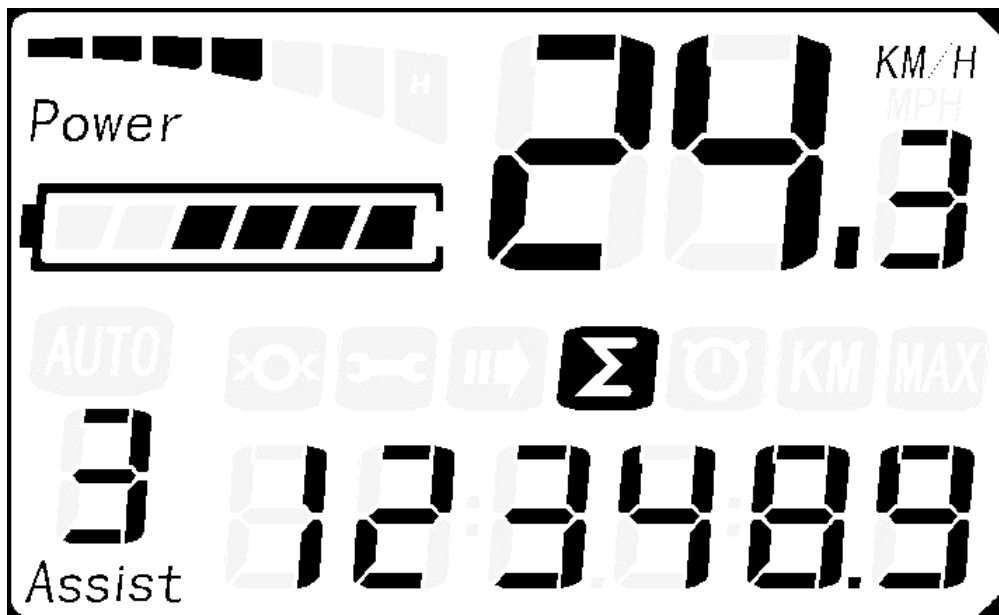

Button Definition

C100 has four buttons. They are **ON/OFF**, **SET**, **UP** and **DOWN**.

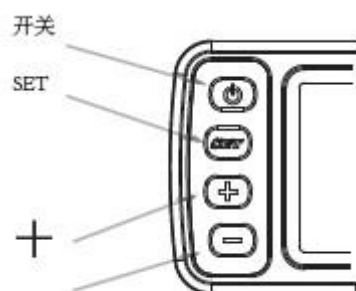

Normal Operation

ON/OFF

Press ON/OFF and start the display , The display will provide power supply for the controller.

With display on , more than 3 seconds press **ON/OFF** to turn off power supply of the e-bicycle. With the display off , the display and controller no longer consume battery power. The leakage current is no more than $2\mu\text{A}$.

※ **If more than 5 minutes without use of the e-bicycle, the display will automatically shut down.**

Display Interface

Press **SET** to switch the displaying information. The order is: ODO → Riding Distance → Riding Time → Max Speed.



ODO Display

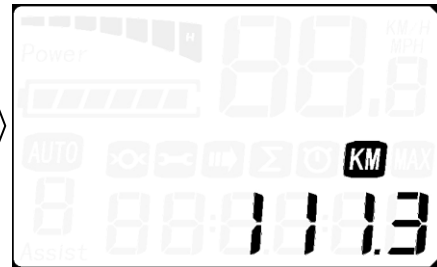

Riding Distance Display

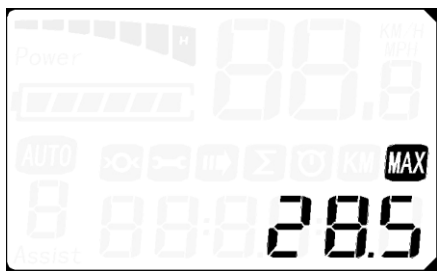

Max Speed Display



Riding Time Display

Push Cruise Control

Hold **UP** for 2 seconds and enter into the mode of power assist walk. The e-bicycle will go on at a uniform speed of 6km/h. It shows "6KM" on the screen.



Turn on/off Backlight

With the display on, press **ON/OFF** and turn on the backlight. Meanwhile, the controller will turn on the headlight. When the surrounding light is not enough or it is in the evening, you can turn on the backlight. And press **ON/OFF** again, turn off the backlight.

PAS Level Selection

Press **UP** or **DOWN**, switch the e-bicycle Assist Level to change output power of the motor. The power ranges from 0~5 levels. The default value is level 3.

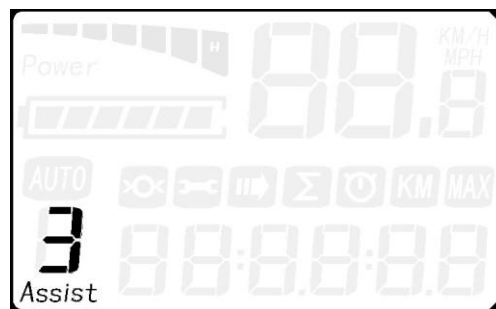

Battery Indicator

When the battery capacity is high, the six battery segments are all light. When the battery is in low voltage, the outside edge of the battery frame will flash at 1 Hz. It indicates that the battery is severely low in voltage condition and needs to be recharged immediately.

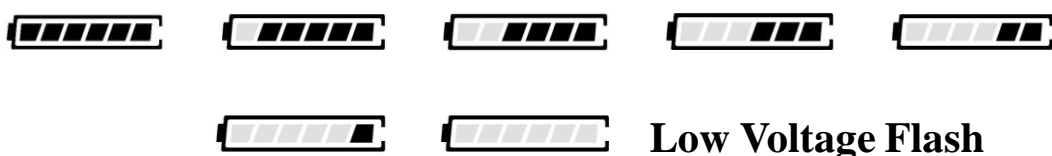

Error Code Display

If there is something wrong with the electronic control system, the display will show the error code automatically. See **Table 1** for detailed error code information.

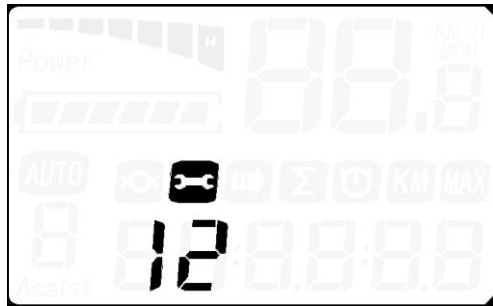

※ **Display return to normal only after problem being fixed and bike will not run before fixing the problem.**

User Setting

Preparation before Starting

Make sure the connector is linked properly to the motor controller on the bike and the power is on.

General Setting

Distance and Riding Time Clearing

- ★ Hold **UP/DOWN/SET** for 1 seconds to clear Total Distance、 Riding Distance, Riding time and Max Speed.
- ★ Hold **DOWN** for 3 seconds to clear Riding Distance and Riding time and Max Speed.

Wheel Size Setting

- ★ Hold **SET** for 10 seconds and enter into wheel diameter setting.

Selectable values include : 16,20,24,26,700C,28.

Press **UP** or **DOWN** to select the suitable value ,

to ensure the accuracy of display about speed and mileage. Default diameter value is 700C.



※ Press UP or DOWN to choose the wheel diameter setting, press SET to exit the setting.

KM/H, MPH Setting

Hold **DOWN** for 9 seconds to switch KM/H and MPH selection. (Default is KM/H)

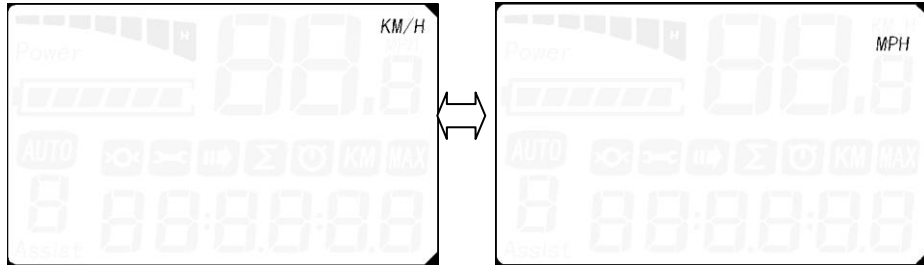

KM/H, MPH Setting

※ Press **SET** to exit the above setting interface.

FAQ

Q: Why the display is not able to start up?

A: Checking the connector that between display and controller.

Q : How to deal with the error code?

A: Fix it to the maintenance place immediately

Quality assurance and Warranty scope

Warranty:

- 1、 Any quality problems in normal case and in guarantee period, our company will responsible for the warranty.
- 2、 The warranty time is 18 months from date of purchasing.

Other items:

The following items are not belong to warranty scope

- 1、 It can not be demolished.
- 2、 The damage caused by wrong installation or operation.
- 3、 Shell is broken when display is out of the factory.
- 4、 Shell is broken when display is out of the factory.
- 5、 Force majored (such as fire, earthquake, etc.) or natural disasters like lightning, etc caused by fault or damage.

6、 Beyond Warranty period.

Error code definition

Error code	Definition
33	Current Abnormality
34	Throttle Abnormality
35	Motor Abnormality
36	Motor Hall Signal Abnormality
39	Low voltage
37	Temperature Abnormality
38	Controller Communication Abnormality

Table 1